

FIRE ATTENUATION SCREEN (MODIFIED)



THE INFORMATION CONTAINED IN THIS DRAWING IS SOLE PROPERTY OF CRIMSAFE SECURITY SYSTEMS PTY LTD. ANY REPRODUCTION IN PART OR AS A WHOLE WITHOUT THE WRITTEN PERMISSION OR AGREEMENT OF CRIMSAFE PRODUCTS IS PROHIBITED. THIS IS A REGISTERED DESIGN UNDER CRIMSAFE SECURITY SYSTEMS PTY LTD.

Crimsafe Australia

Phone:+61 7 5540 7588

Fax:+61 7 5549 3735

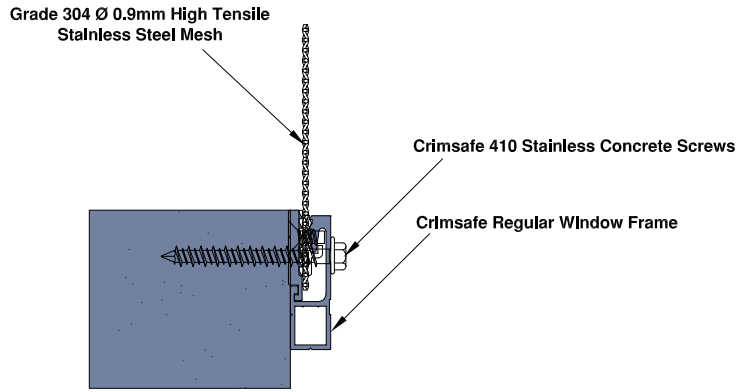

Figure 1 - Reveal fixed to Masonry or Concrete Walls

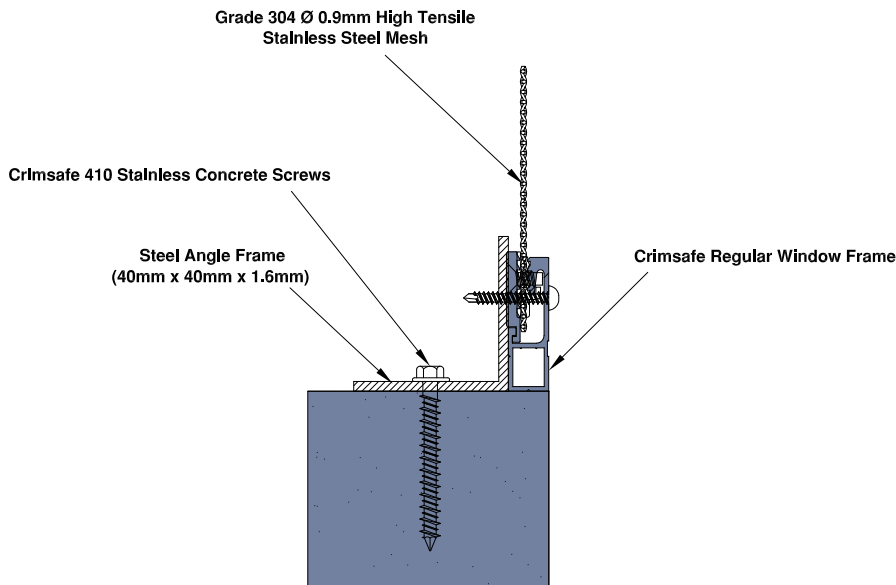

Figure 2 - Reveal fixed to Masonry or Concrete Walls with Steel Angles

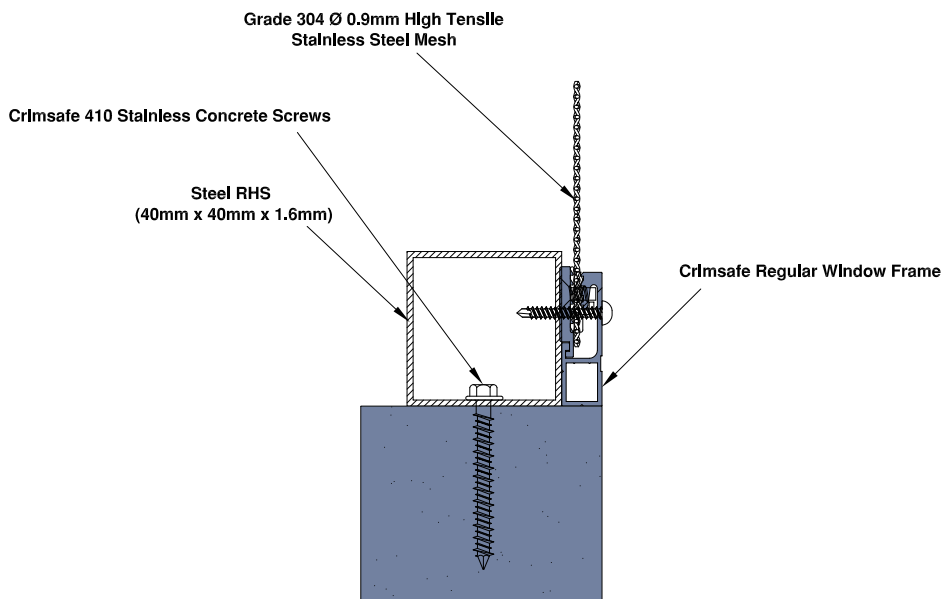

Figure 3 - Reveal fixed to Masonry or Concrete Walls with Steel Tubes

Product:
STANDARD WINDOW

Rev.	Description

DRAWN BY:	Krittaya D.	13 SEP 17
CHECKED BY:	Ramesh R	13 SEP 17
APPROVED BY:	Ramesh R	13 SEP 17

1:1, A2

INTERNAL DWG CODE:
U_ATB_H600

Sheet
1 of 1